

Electrostatic Control of Suspended Test Masses for Gravity Wave Detectors



Honours 2002

Ben Lee

Supervisors:

Professor David Blair
Dr Ju Li

Introduction – Gravitational Wave Radiation

-The Gravitational Wave-

- Illuminates from all non-spherical motion of matter in space.
- Couples weakly to matter, causing it to oscillate in a quadruple fashion.

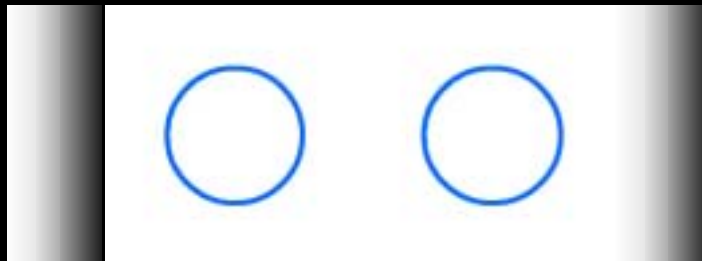

- Typically, the deformation is such that $\Delta L/L < 10^{-18}$.

Introduction – Gravitational Wave Radiation

-Gravitational Wave Detection-

- The detection of gravity wave radiation involves detecting the quadruple deformations
- An interferometric detector is ideal for such a task.

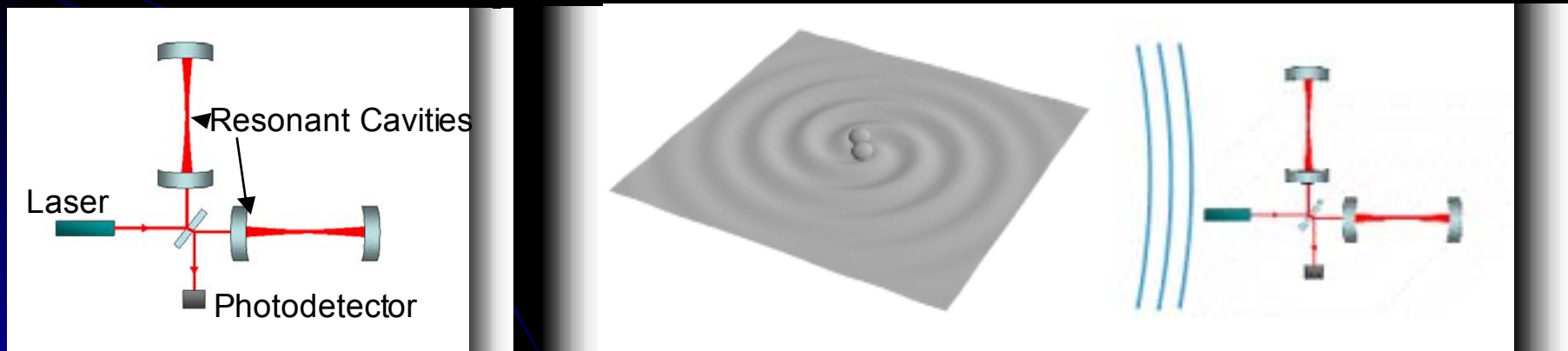

Introduction – Gravitational Wave Radiation

-Interferometric Based Antenna-

- Interferometer sensitivity limits need to be minimized.

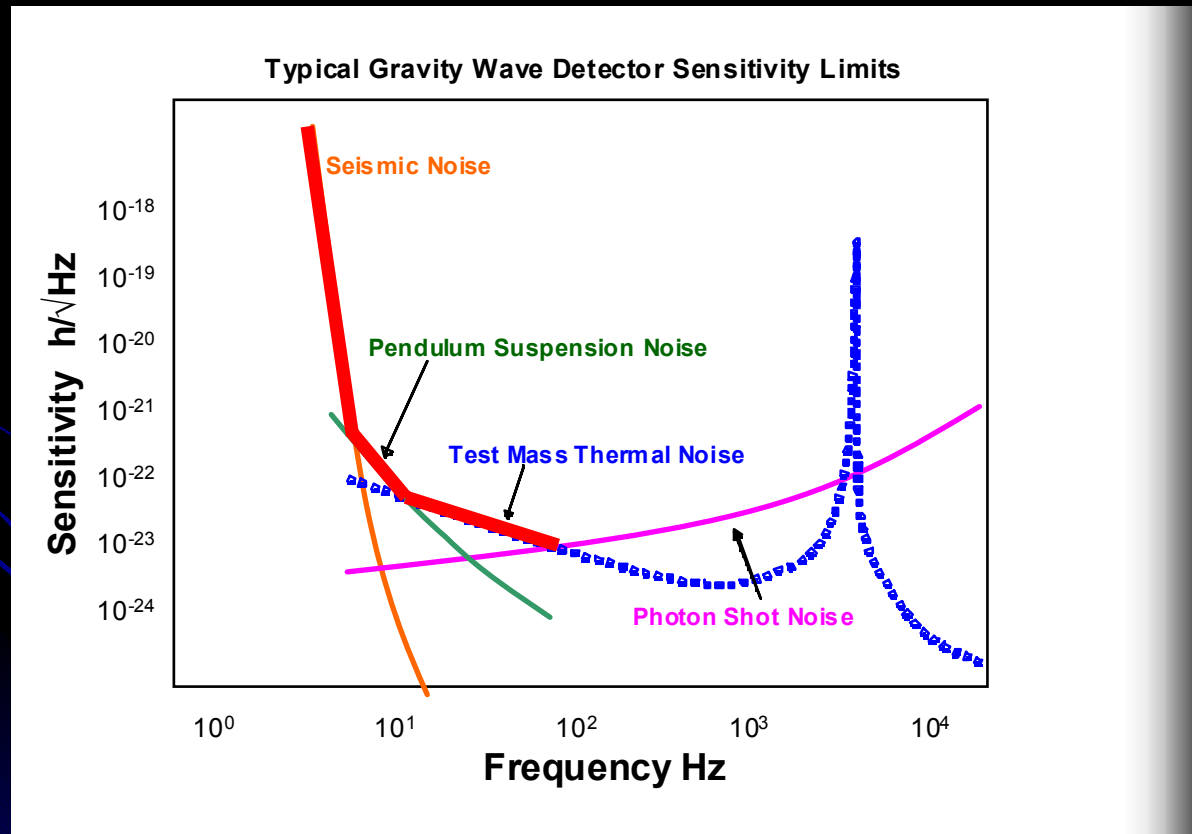

The Control Mass

-Final Vibration Isolation Stage-

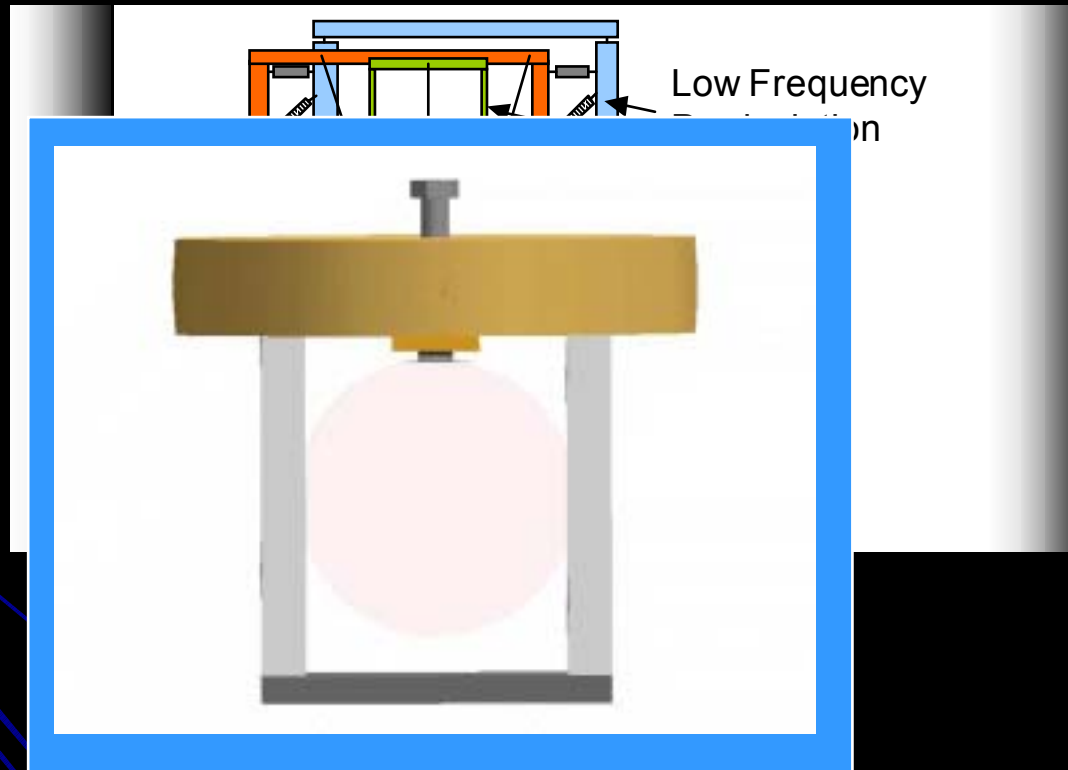

- The test mass is suspended from a control mass stage, located at the bottom of the vibration isolation system

The Test Mass and its Suspension

-Current Designs-

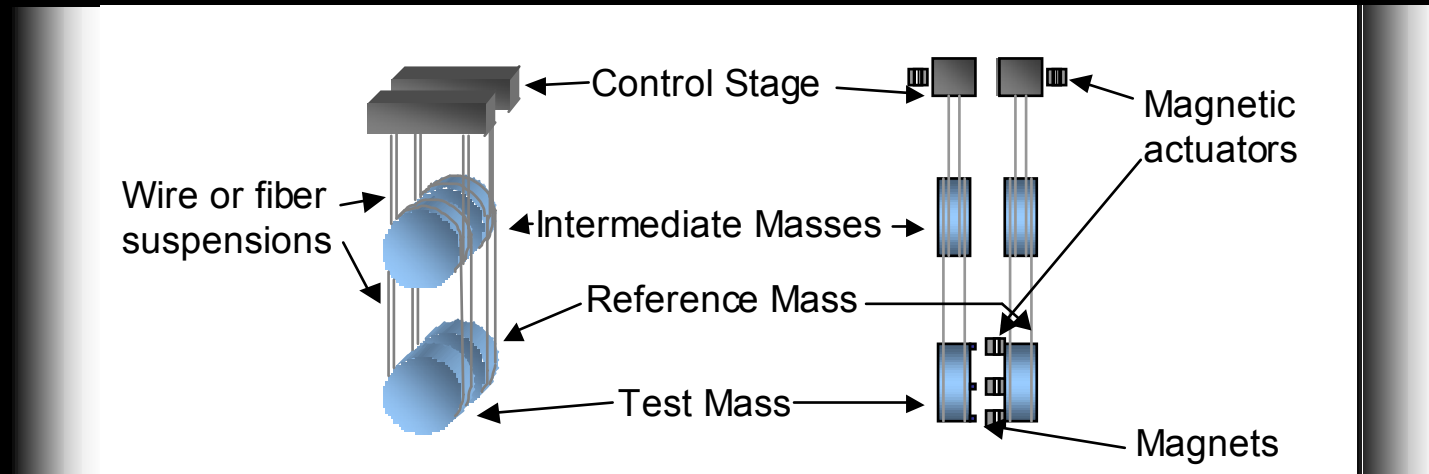

- Current suspension techniques involve the use of wire or fiber suspensions. Test mass fine control and steering is achieved with magnets attached to the test mass surface.

The Electrostatic Actuator

-The Force Exerted by a Capacitor-

- For a simple plate capacitor, it can be shown that the for a constant voltage between the plates, the following equation holds:

$$F = \frac{1}{2} V^2 \frac{dC}{dx}$$

- The actuator design consists of a combo of interwoven electrodes

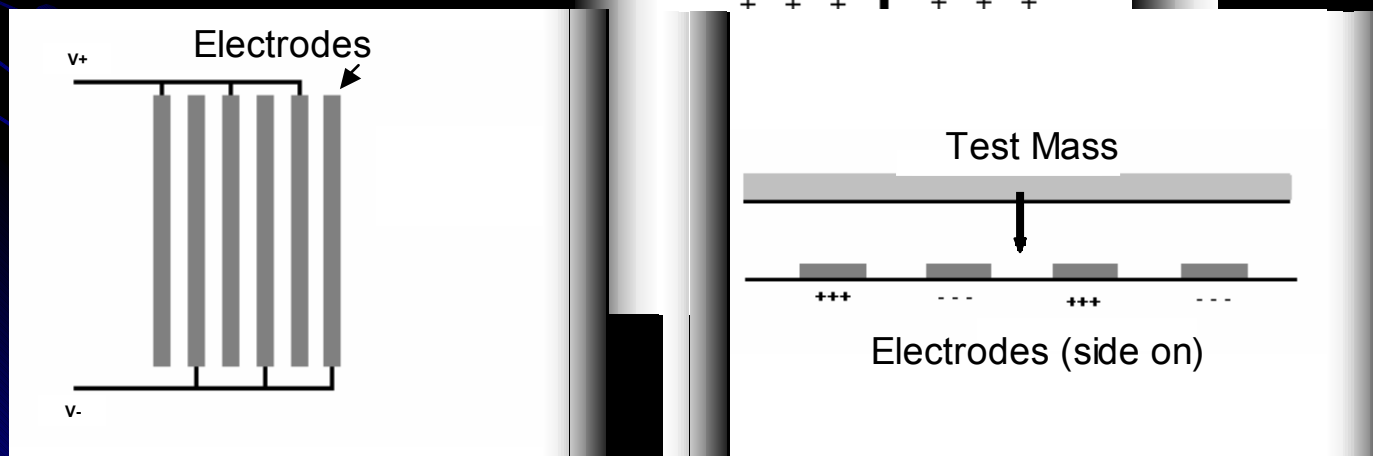

The Electrostatic Actuator

-The PCB layout-

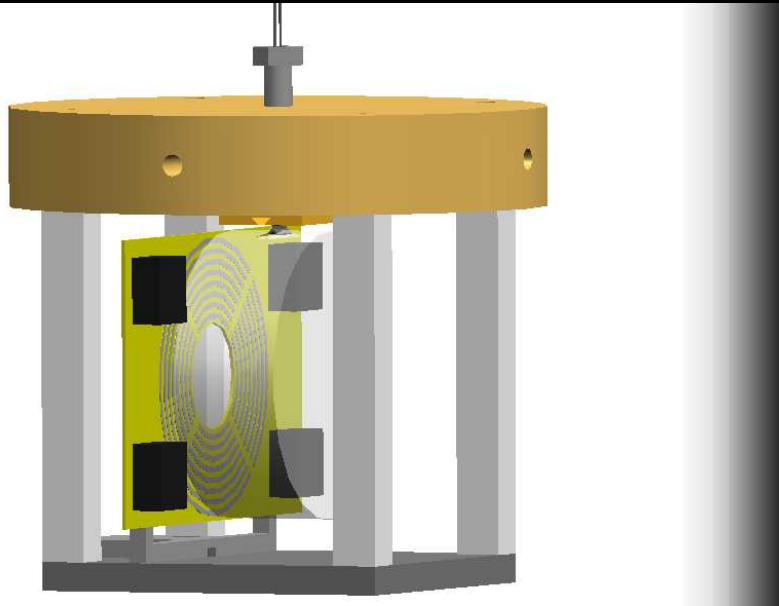

- The arrangement of the electrodes allows for the actuation of 3 test mass modes, translation rotation and tilt.

The Electrostatic Actuator

-The Actuator Performance-

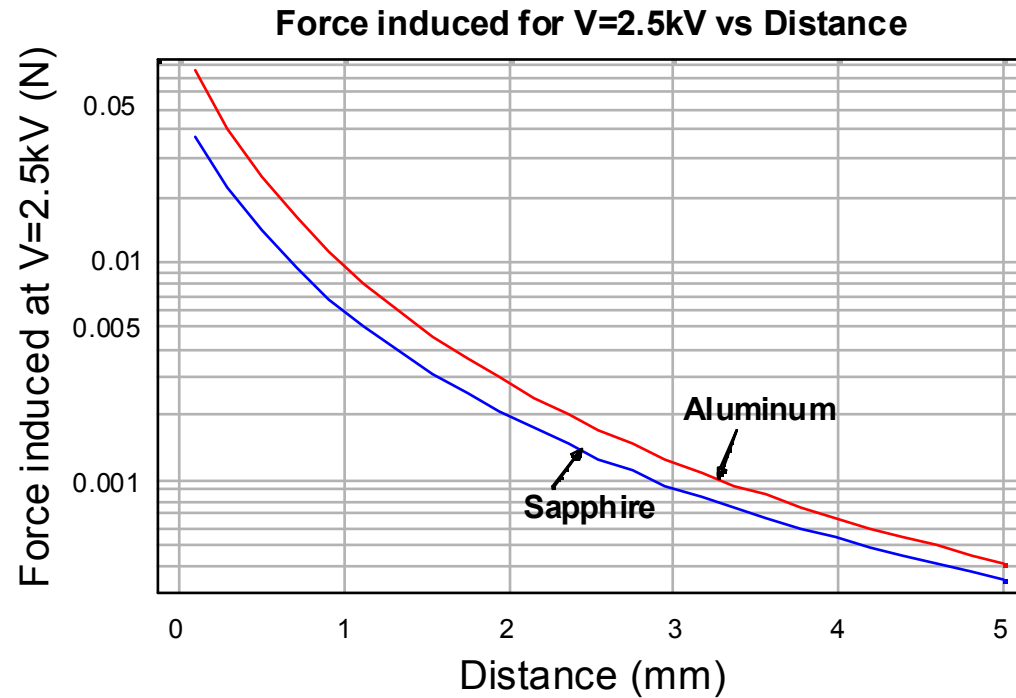

The Electrostatic Actuator

-The Actuator Speed-

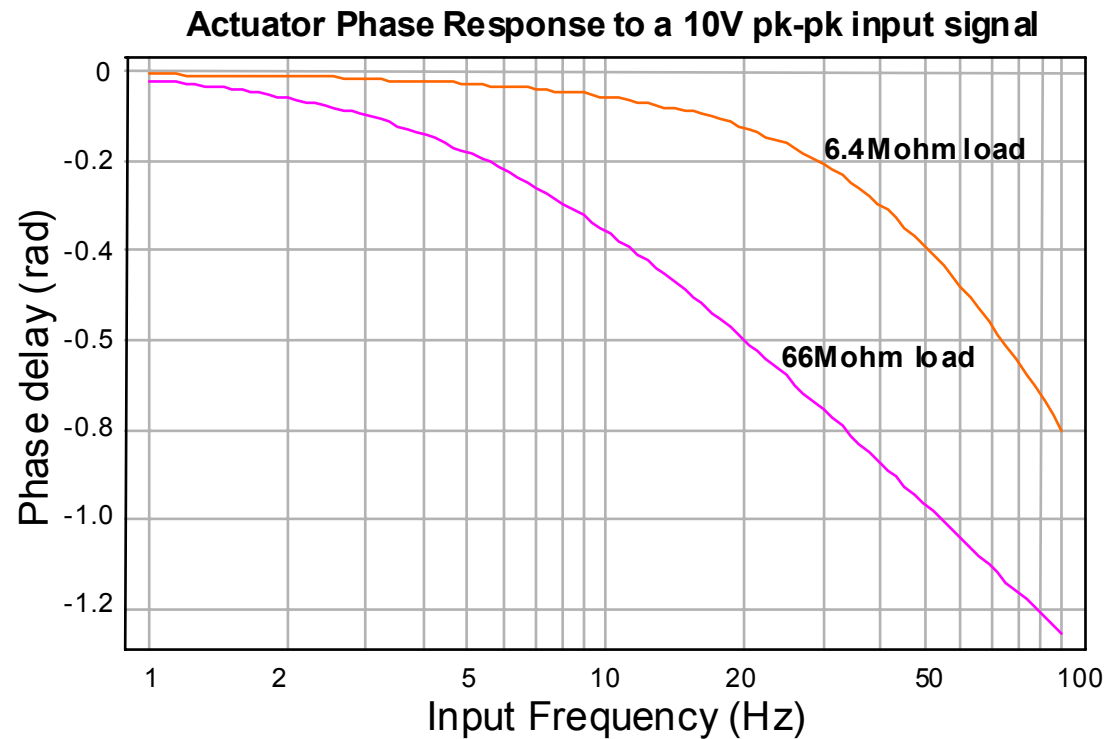

Digital Control System

-The Proportional, Integral, Derivative Controller-

- The PID feedback controller was used for test mass control due to its ability to efficiently cope with transient and steady state followings.
 - The P and I terms provide both low frequency control and the ability to move the test mass to newly defined setpoints when necessary.
 - The D feedback provides loop stability and active damping.

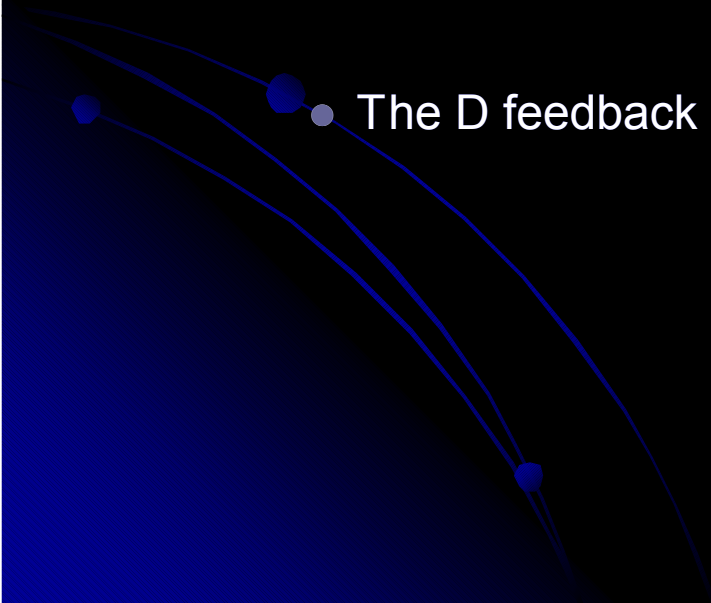

Digital Control System

-The Proportional, Integral, Derivative Controller-

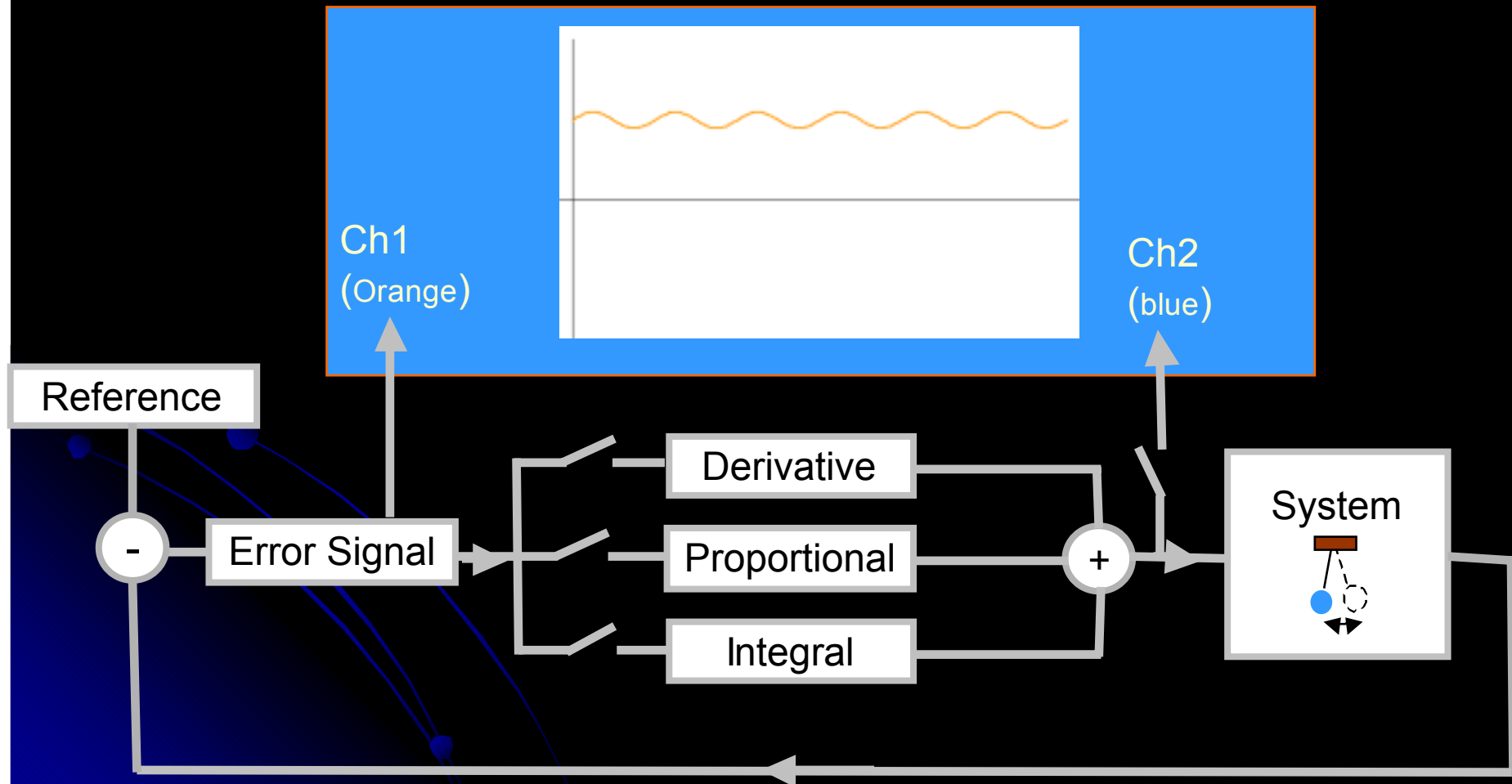

Digital Control System

-The Proportional, Integral, Derivative Controller-

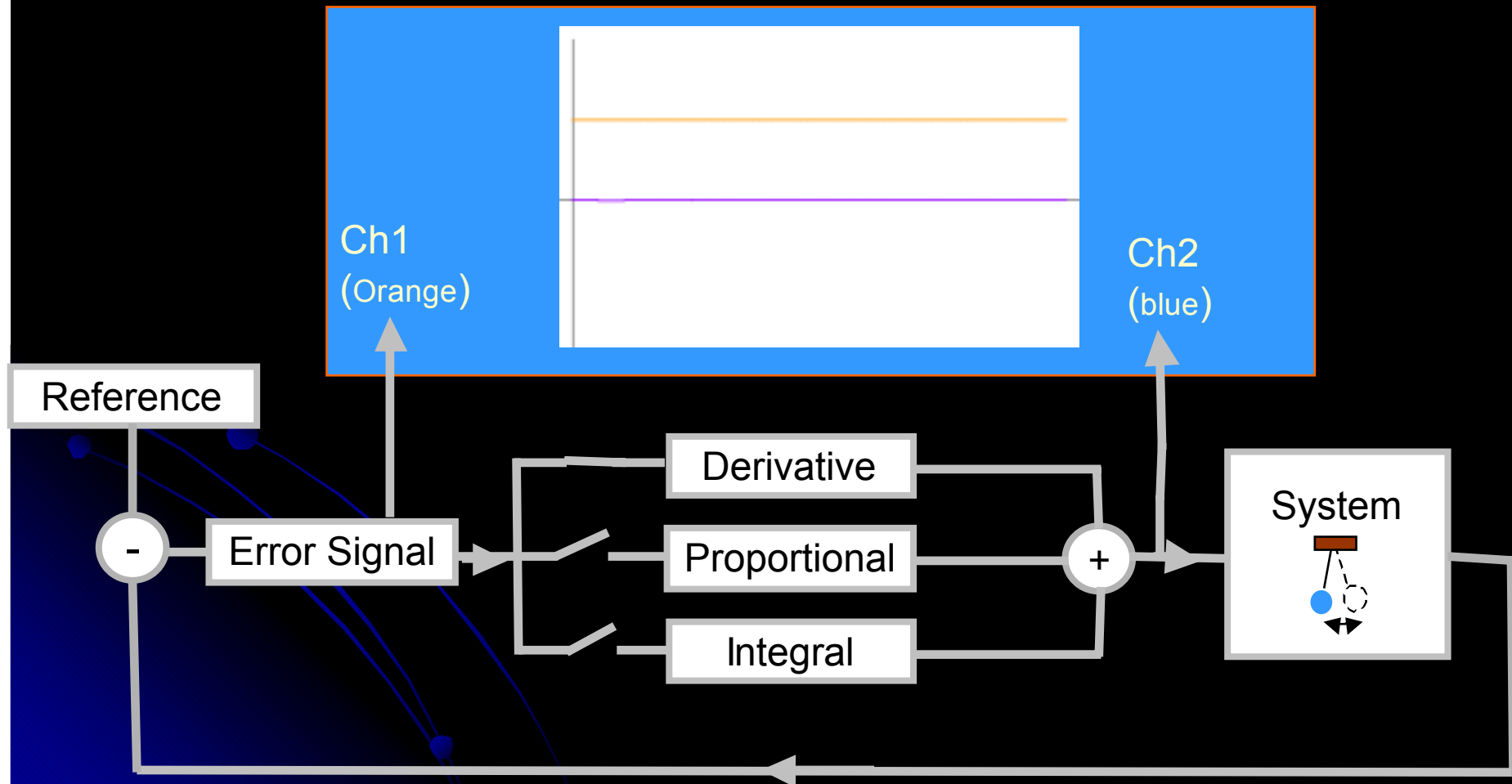

Digital Control System

-The Proportional, Integral, Derivative Controller-

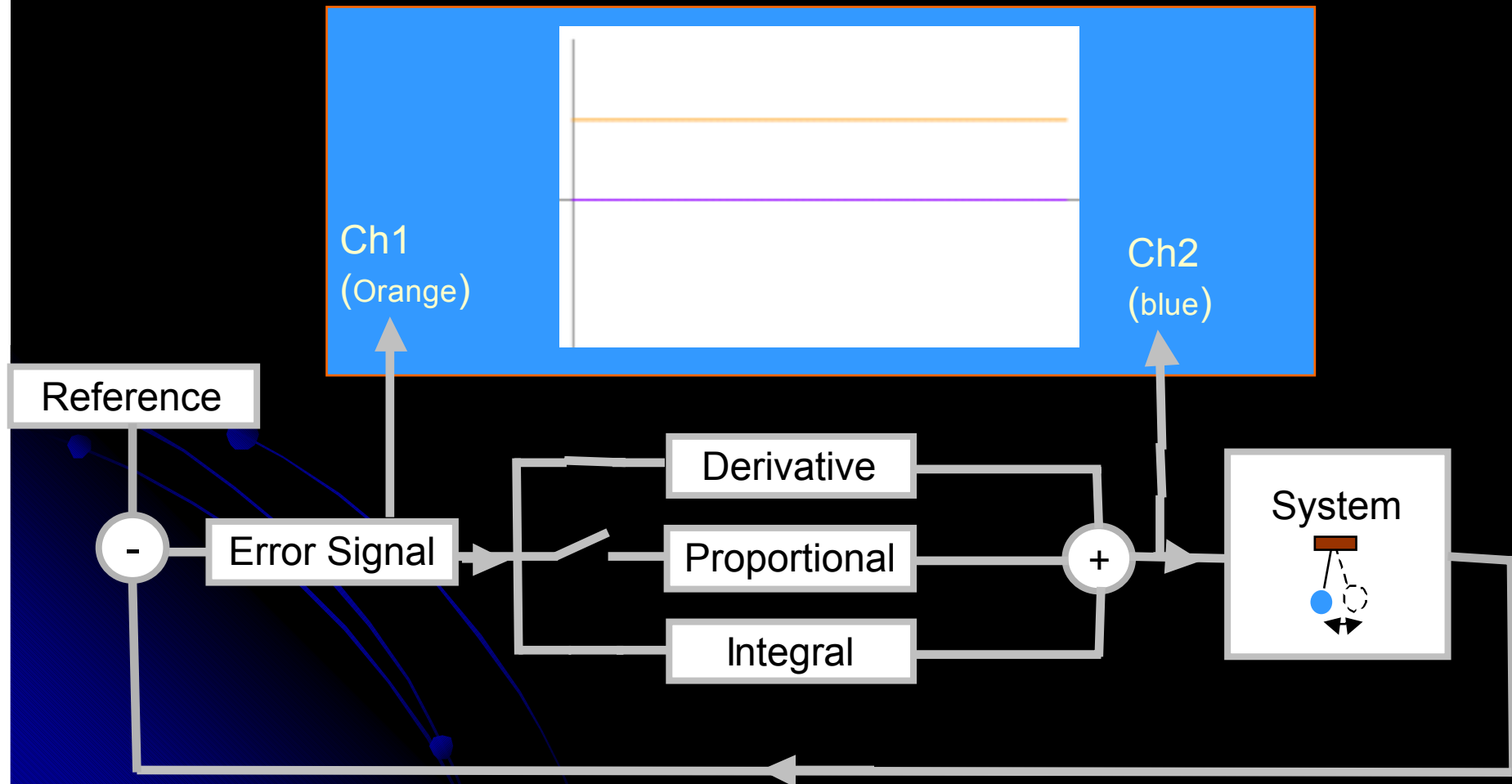

Test Mass Control

-The Sensor Arrangement-

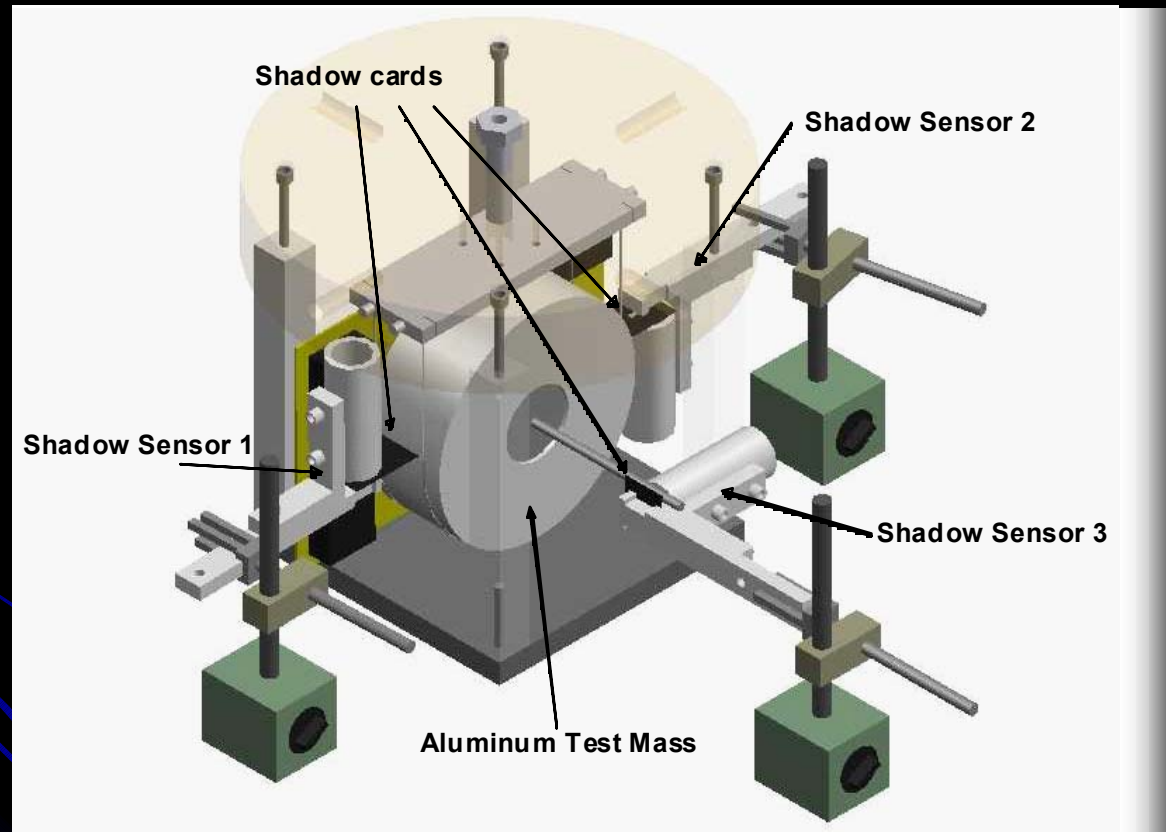

- Translation, Rotation and Tilt signals are obtained through 3 shadow sensors arranged as illustrated.

Test Mass Control

-2-Wire Suspension Translation Control-

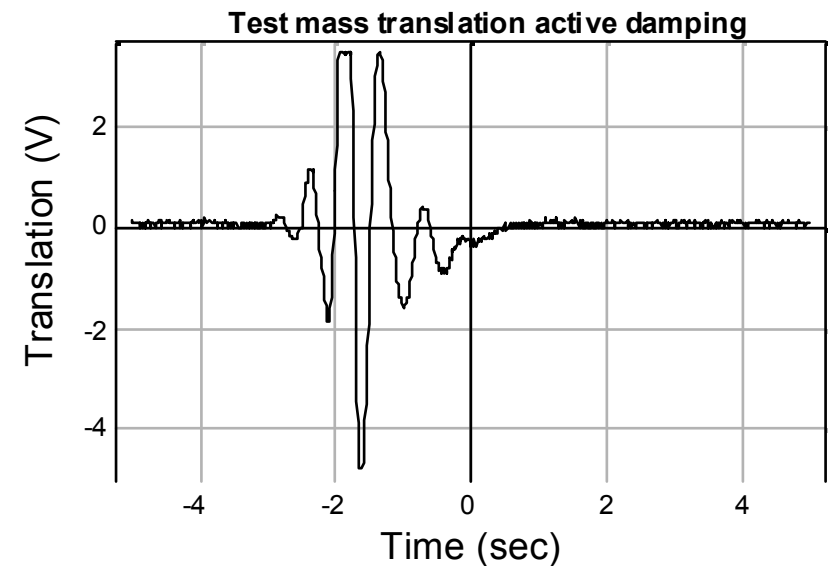
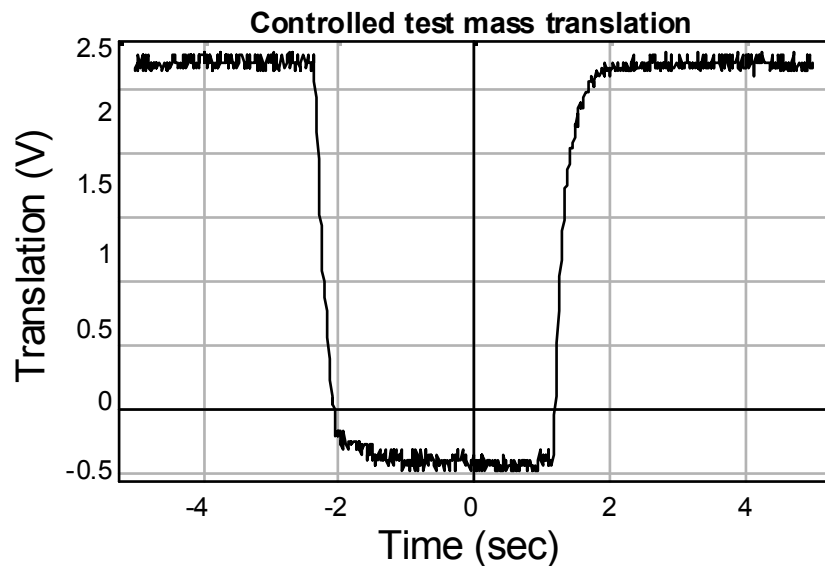

- The effects of steady state following and active damping can be altered through changing the P and D gains respectively.

Test Mass Control

-2-Wire Suspension Decoupling-

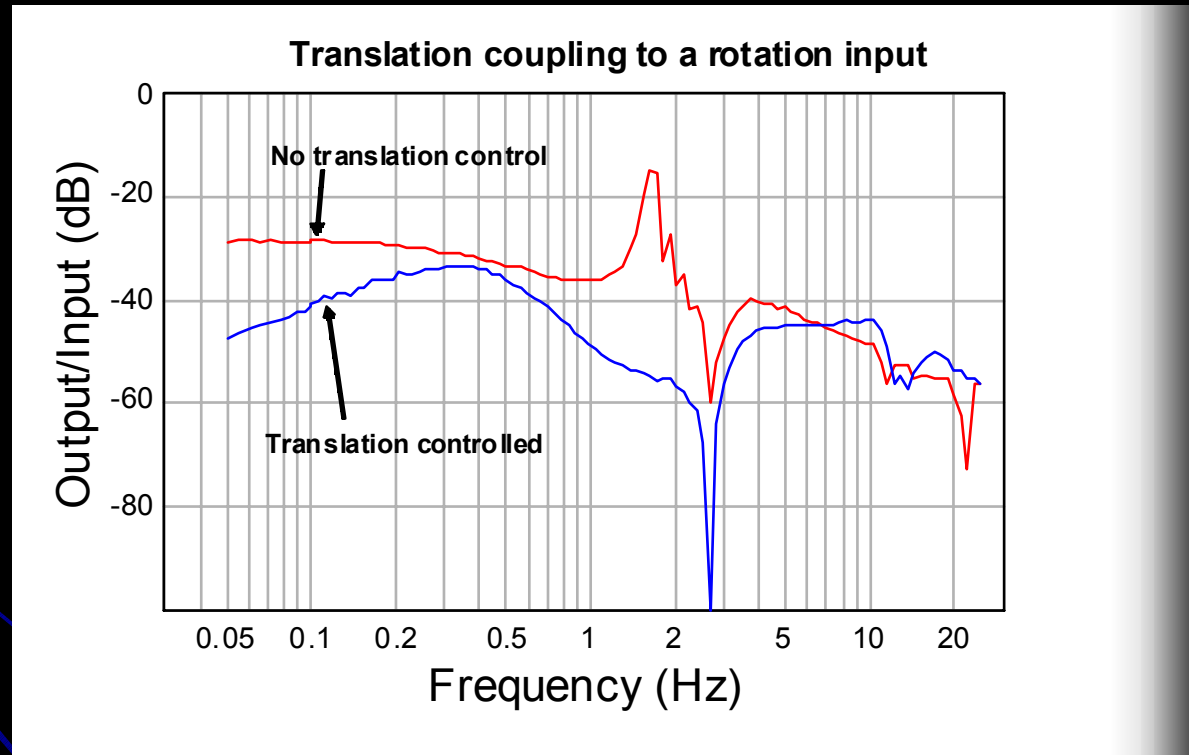

- The independent control loops most effectively reduce the translation to rotation coupling at low frequency.

Test Mass Control

-Flexure Suspension Tilt-Translation Decoupling-

- The test mass suspension point of the flexure suspended test mass means that Tilt is strongly coupled to Translation.

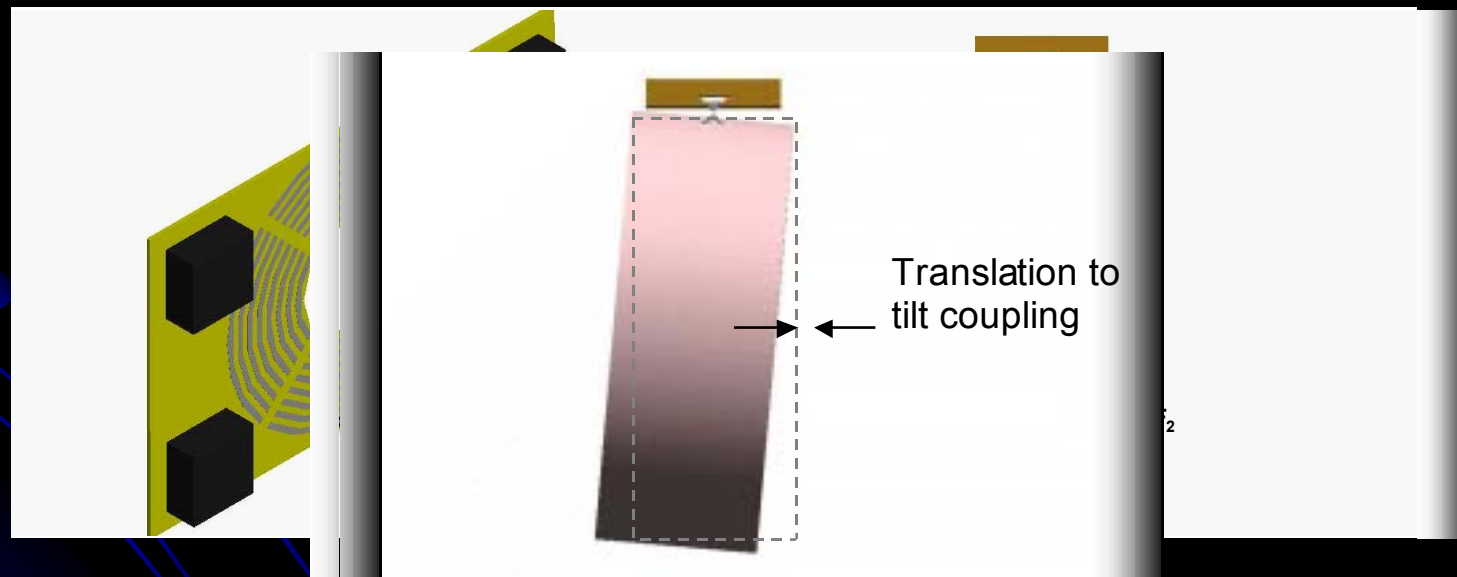

- To minimize this coupling, the ratio of the forces applied by the top and bottom actuators is changed.

Test Mass Control

-Flexure Suspension Tilt-Translation Decoupling-

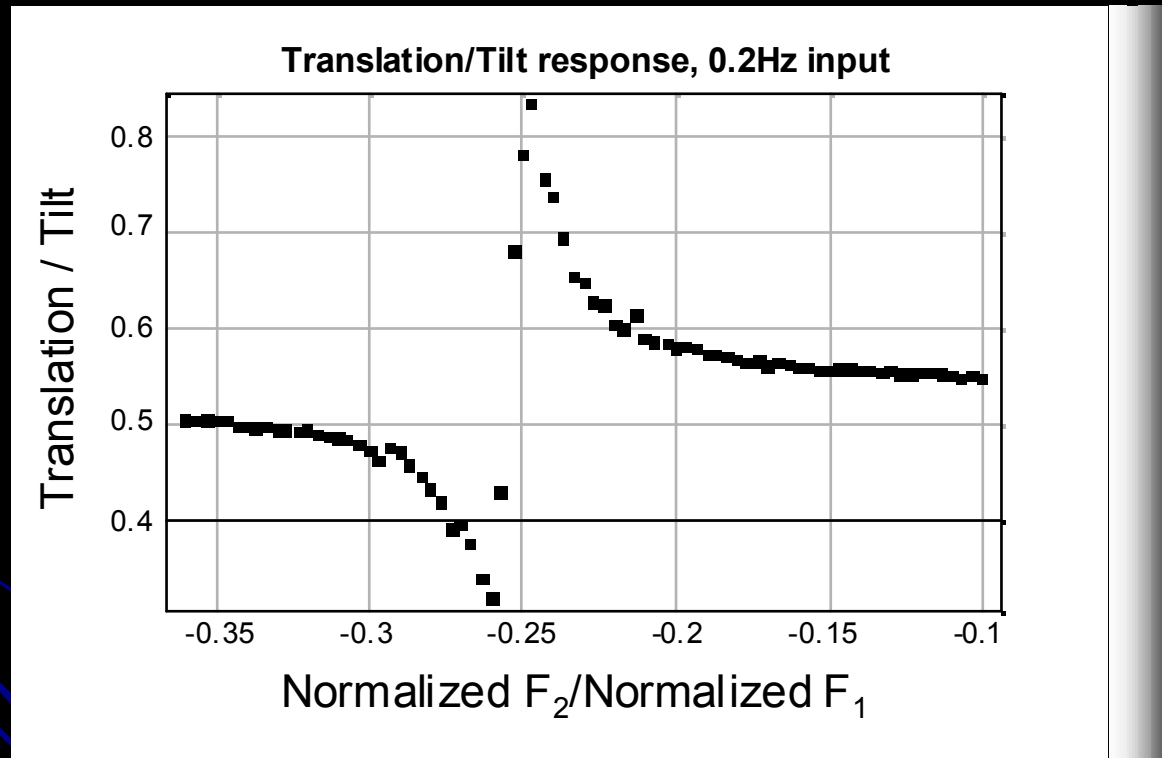

- The result illustrates maximum decoupling for a ratio of $F_2/F_1 = -0.24$

Conclusions

-Electrostatic Test Mass Control-

- It is found that an electrostatic actuator, such as the one presented, can adequately control the tilt of a flexure suspended test mass.

- It is also capable



tor is not

Conclusions

-Future Work-

- Translating actuators to be incorporated at the control mass stage.
- Development of an 'intelligent' control system to decouple translation and tilt.

